

USE AND CHARACTERIZATION OF LINEAR NOZZLES
FOR SPRAY FORMING

David D. León and Robert L. Kozarek

Aluminum Company of America (Alcoa)
Alcoa Technical Center
100 Technical Dr.
Alcoa Center, PA 15069-0001

RECEIVED

OCT 27 1995

OSTI

ABSTRACT

Commercial production of aluminum sheet and plate by spray atomization and deposition is a potentially attractive manufacturing alternative to conventional ingot metallurgy/hot-milling, and to continuous casting processes because of reduced energy requirements and reduced cost. To realize the full potential of this technology the Aluminum Company of America (Alcoa), under a cooperative agreement with the U. S. Department of Energy, has investigated currently available state-of-the-art atomization devices to develop nozzle design concepts whose spray characteristics are tailored for continuous sheet production. This paper will discuss Alcoa's research and development work on three linear nozzle designs. The effect of geometry and process parameters on spray pattern and particle size distribution will be presented. The discussion will focus on the final spray formed deposit produced by these deposition systems.

INTRODUCTION

Over the past several years, continuous casting of aluminum has been gaining acceptance for the production of low-alloy sheet products, replacing more conventional ingot metallurgy/hot mill processes. This trend has evolved into the near-net-shape casting of sheet and plate preforms because of their cost reduction benefits. The advantages of any one technique lie in its ability to eliminate energy intensive, high capital cost process steps. Figure 1 compares the three most common methods for manufacturing aluminum reroll stock.

Spray forming is a technology based on the atomization of liquid melts and subsequent deposition on a substrate. A sketch of the spray formed sheet process is shown in Figure 2.

DISCLAIMER

This report was prepared as an account of work sponsored by an agency of the United States Government. Neither the United States Government nor any agency thereof, nor any of their employees, makes any warranty, express or implied, or assumes any legal liability or responsibility for the accuracy, completeness, or usefulness of any information, apparatus, product, or process disclosed, or represents that its use would not infringe privately owned rights. Reference herein to any specific commercial product, process, or service by trade name, trademark, manufacturer, or otherwise does not necessarily constitute or imply its endorsement, recommendation, or favoring by the United States Government or any agency thereof. The views and opinions of authors expressed herein do not necessarily state or reflect those of the United States Government or any agency thereof.

MASTER

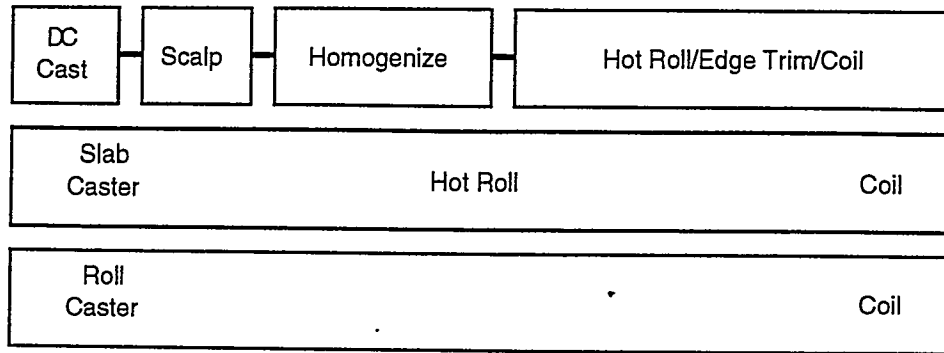

Figure 1. Comparison of the Three Most Common Methods for Manufacturing Aluminum Reroll Stock

The use of spray deposition to produce aluminum sheet and strip was first investigated in the 1970's [1]. In addition to eliminating several process steps, spray formed material is metallurgically superior to continuous cast materials because of the following characteristics:

- Uniform distribution of equiaxed grains ($<200 \mu\text{m}$)
- No macroscopic segregation of alloying elements
- Extension of the solid solubility of the alloy
- Uniform distribution of second phases
- Improved tolerance to impurities
- Low oxide content

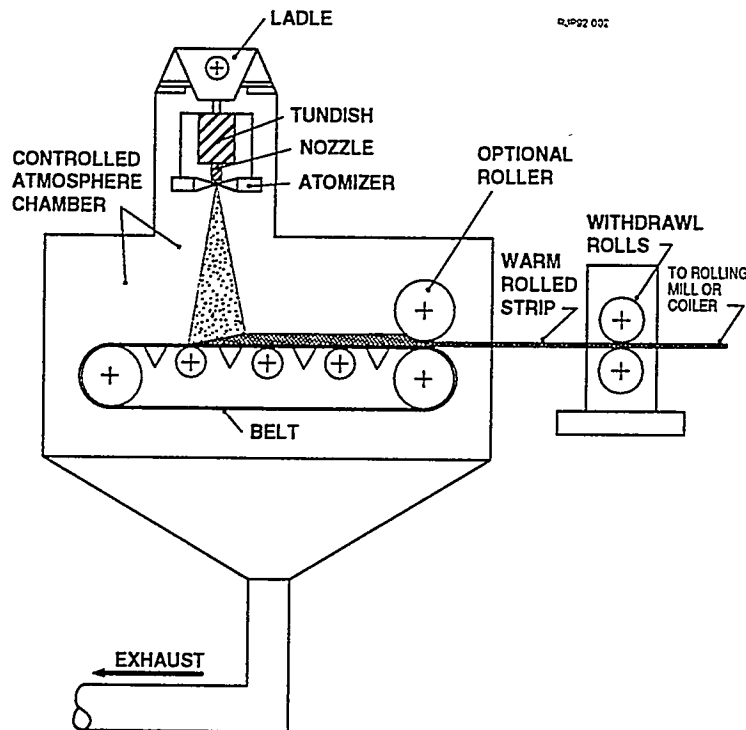

Figure 2. The Spray Formed Sheet Concept

In addition, spray forming offers an advantage due to its ability to incorporate ceramic particulate into metal matrix composites.

Equipment & Process Description

The application of linear nozzles for spray forming was first investigated under Phase I of the U. S. Department of Energy's Metals Initiative Program. Linear nozzles were selected because of their advantage in production rate, minimization of overspray and improved flatness for wide sheet.

Alcoa has performed research and development work on three linear nozzle designs: N. Grant's Ultrasonic Gas Atomizer (USGA) nozzle and two Alcoa designs (Alcoa I and Alcoa II). These nozzles are all described below and shown schematically in Figure 3. Parallel work was performed under contract at the Idaho National Engineering Labs (INEL) using DeLaval type nozzles and will not be covered in this paper.

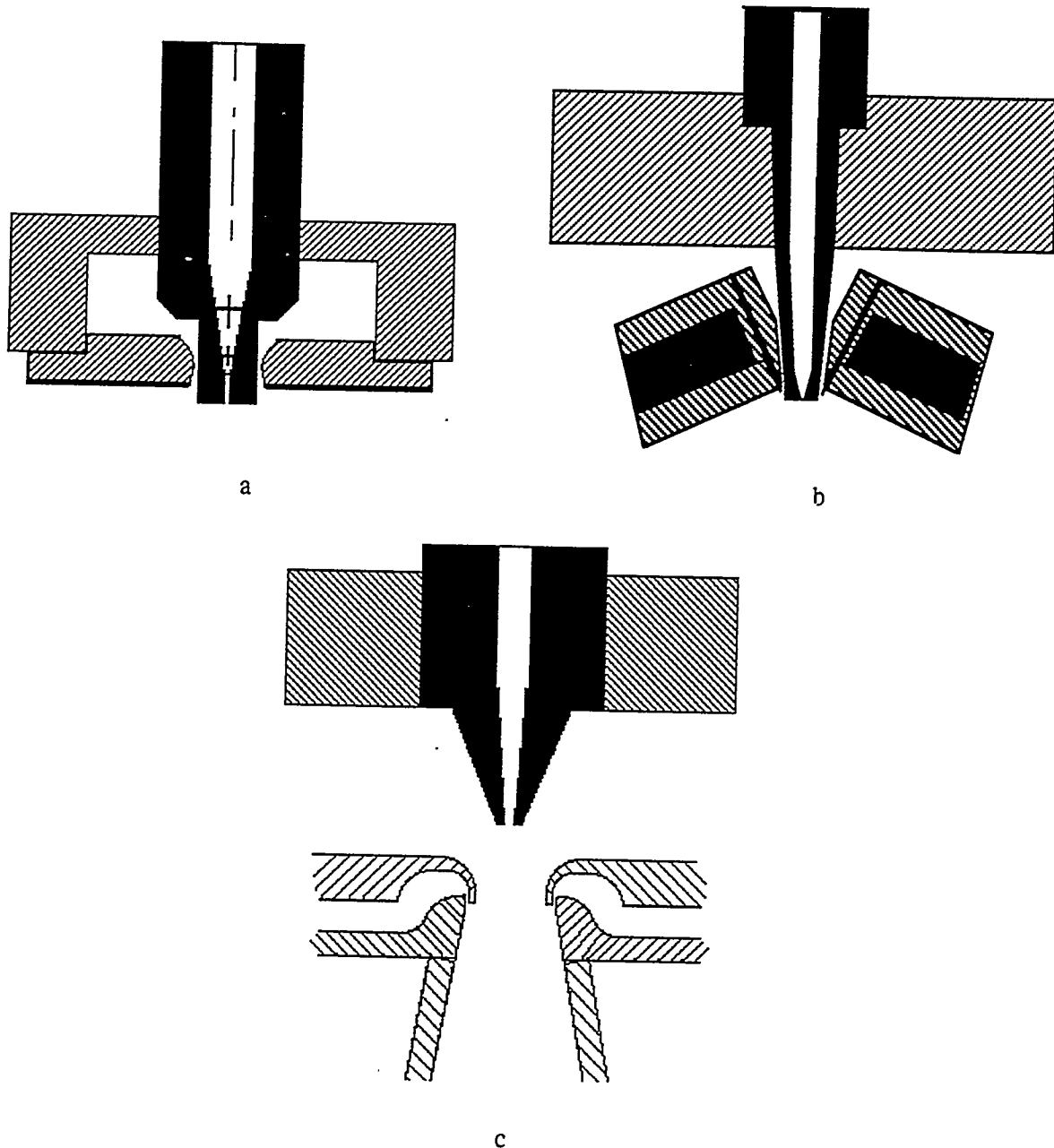

Figure 3. Spray Forming Nozzle Concepts
(a. ALCOA I b. USGA c. ALCOA II)

The USGA nozzle provides a typical example of the Confined-Liquid Gas Atomizer, in which the metal delivery tube is situated in close proximity to the high velocity gas jets [2]. The aerodynamic interactions between the gas jets and the metal delivery tube affect the pressure at the liquid metal exit causing non-free fall metal delivery. In this linear nozzle design the gas jets consist of rectangular slits placed on either side of the confined liquid metal nozzle. An integral part of this design is the use of Hartman shock tubes to provide ultrasonic energy to the melt, aiding atomization.

The Alcoa I nozzle also uses the confined-liquid technique to promote atomization. The major difference is in the method and geometry used to develop full gas flow at the point of contact with the liquid. Its main feature is the DeLaval type exit geometry on the gas side.

The above designs have the advantage of close-coupling the gas and liquid providing for very energy-efficient systems. Unfortunately, one of their main drawbacks is their reduced operating window. This is due mainly to the complex way in which the operating variables interact.

The Alcoa II nozzle provides a typical example of an unconfined-liquid gas atomizer, in which the metal delivery tube is situated above the high velocity gas. The liquid metal is allowed to free fall into the atomizing zone produced by the intersecting gas jets. In this system the gas is introduced through a slit that completely surrounds the metal stream to improve atomization and gas distribution at the ends of the nozzle. Although less efficient, the de-coupling of the liquid and gas feeds has the advantage of widening the spray forming operating window. This nozzle design also introduced the use of extended shrouds to contain the spray plume.

At the start of the Spray Forming Project, Alcoa performed a review of the important parameters related to nozzle development and performance. Table 1 shows the most important parameters noting the tested range of each one.

Table 1. List of Important Variables for Nozzle Development

Variable	Measurable Effect	Range
Gas Side Vertical Offset (V)	<ul style="list-style-type: none"> • Gas velocity profile • Substrate deposition profile • Recirculation • Overspray 	-0.875" to +0.45"
Air gap (H)	<ul style="list-style-type: none"> • Gas velocity profile • Substrate deposition profile • Recirculation • Overspray 	1.35" to 0.00"
Jet angle (α)	<ul style="list-style-type: none"> • Gas velocity profile • Substrate deposition profile • Recirculation • Overspray 	5° to 30° (USGA) n/a (Alcoa I & II)
Gas pressure (P)	<ul style="list-style-type: none"> • Gas velocity profile • Substrate deposition profile • Recirculation • Overspray • Particle size distribution 	20 to 110 psi
Gas slit width (W_g)	<ul style="list-style-type: none"> • Gas:Metal ratio • Particle size distribution 	0.020" - 0.040"

Table 1 (cont.). List of Important Variables for Nozzle Development

Variable	Measurable Effect	Range
Gas slit length (L_g)	<ul style="list-style-type: none"> • Gas:Metal ratio • Particle size distribution • Gas:Metal slit ratio 	2" to 8"
Metal Side Alloy	<ul style="list-style-type: none"> • Solidification rate • Mechanical & physical properties 	Pure Al, 3XXX, 1XXX Future 7XXX, 2XXX, 6XXX
Superheat (SH)	<ul style="list-style-type: none"> • Solidification rate • Particle size distribution 	180° to 285°F
Metal slit width (W_m)	<ul style="list-style-type: none"> • Gas:Metal ratio • Particle size distribution 	0.020" - 0.040"
Metal slit length (L_m)	<ul style="list-style-type: none"> • Gas:Metal ratio • Particle size distribution • Gas:Metal slit ratio 	1.0" - 3.5"

RESEARCH & DEVELOPMENT

The phenomenon by which nozzle geometry and process parameters affect the atomizing spray pattern has been studied extensively. Qualitatively, it is known that the spray pattern will affect the final deposit. Because of the large number of possible combinations of nozzle parameters, Alcoa applied a multi-step approach, using various monitoring techniques to find a set of parameters that would provide the narrowest, most uniform spray distribution.

Spray visualization was the first step in the characterization of spray forming nozzles. Photographic techniques were used to check for spray uniformity and atomization characteristics. Appendix I contains various photographs showing the atomizing phenomena using water as the liquid medium.

Dynamic pressure measurements provide an indication of the gas velocity profile within the spray plume. These gas flow patterns have characteristically given profiles similar to the liquid spray patterns. Measurements were taken using 1/16th inch diameter pitot tubes. The dynamic pressure in the spray plume was measured as a function of gas pressure, gas jet angle, and vertical offset. The technique is similar to that reported by Moir & Jones [3]. Appendix II contains various samples of the contour plots developed showing the effect of the various nozzle parameters on the spray plume. Of main importance is:

1. The width of the plume
2. The peak pressure
3. How fast the plume's dynamic pressure decays.

Phase Doppler Particle Analysis (PDPA) was used to determine particle size and velocity in the spray plume as the next step in the characterization of spray forming nozzles. Parallel work, using water as the liquid medium, was performed both at the Alcoa Technical Center and at the Combustion and Spray Labs of Carnegie-Mellon University (CMU). The PDPA served as verification of droplet size and velocity distributions to ensure that there were not any peculiarities for a particularly promising nozzle arrangement.

Alcoa's Phase Doppler measurements were taken at four different downstream (vertical) distances. The zero distance point was defined at the liquid pour tube exit. Figures 4 and 5 show PDPA particle size and velocity data collected using the USGA nozzle at 20 psi gas pressure.

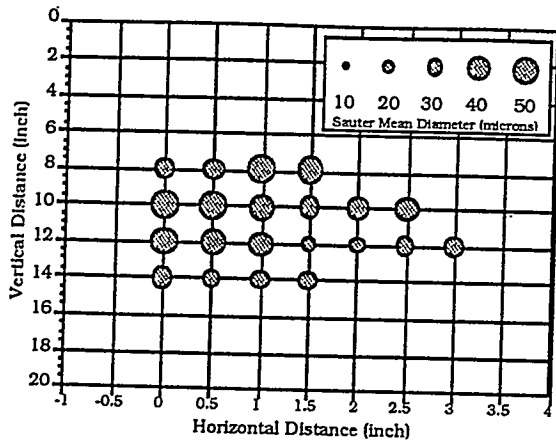

Figure 4. Alcoa PDPA Data - Sauter Mean Diameter

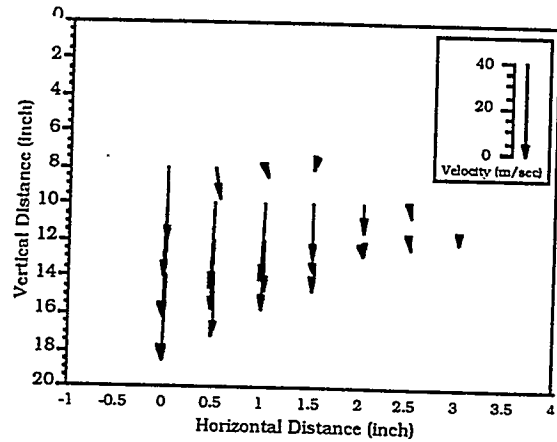

Figure 5. Alcoa PDPA Data - Velocity Profile

CMU's Phase Doppler measurements focused on the effect of gas pressure on the droplet velocity and size in the spray plume. Their data was taken at a downstream distance of 9.5 inches. As before, the zero distance point was defined at the liquid pour tube exit. Figures 6 and 7 show PDPA particle size and velocity data collected using the USGA nozzle as a function of gas pressure.

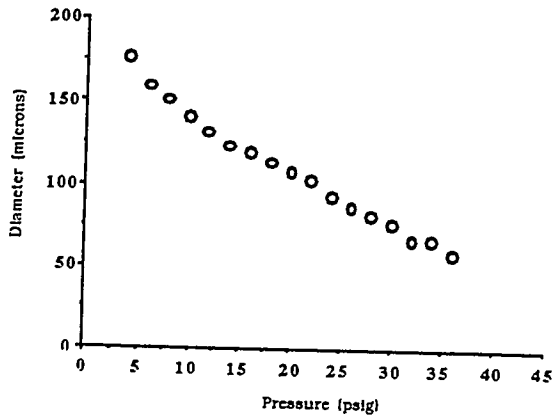

Figure 6. PDPA Data - Sauter Mean Diameter

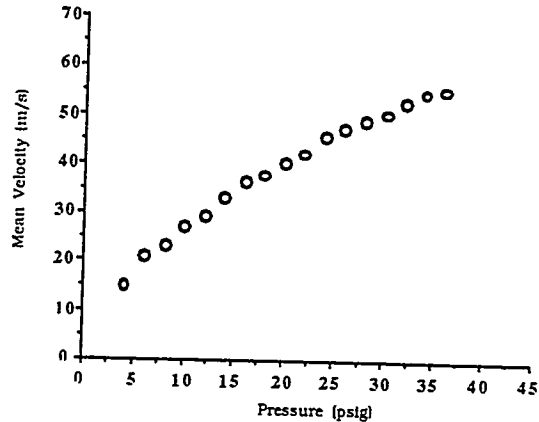

Figure 7. PDPA Data - Velocity Profile

Deposition Studies were performed in two phases:

1. Deposition studies with water using a test tube rake.
2. Deposition studies with molten metal.

Water spray tests are a convenient method to evaluate the effect of a large number of nozzle operating parameters and design changes on the mass distribution of the spray. These mass flux profiles were done by collecting water in a series of test tubes swept across the top of a substrate at the tested deposition length (see Figure 8). By taking multiple passes of the tube rake through the spray plume, at a constant velocity, we were able to average out any time dependent

heterogeneities. A series of profiles, denoting the effect of various nozzle parameters, has been included in Appendix III. In order to compare the various profiles, we calculated a "flatness" parameter, based on the standard deviation of the data over a six inch width across the deposit. Figure 9 compares the effect of pressure and nozzle design on the flatness of the profile.

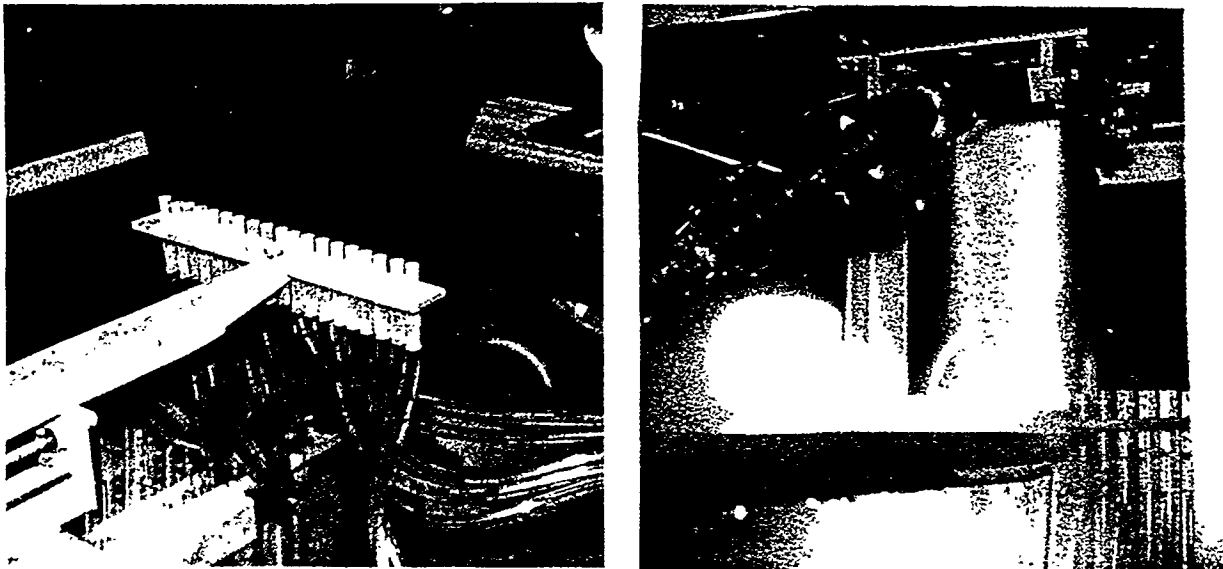

Figure 8. Equipment Used to Monitor the Effect of Nozzle Geometry and Process Parameters on the Deposit Profile Flatness.

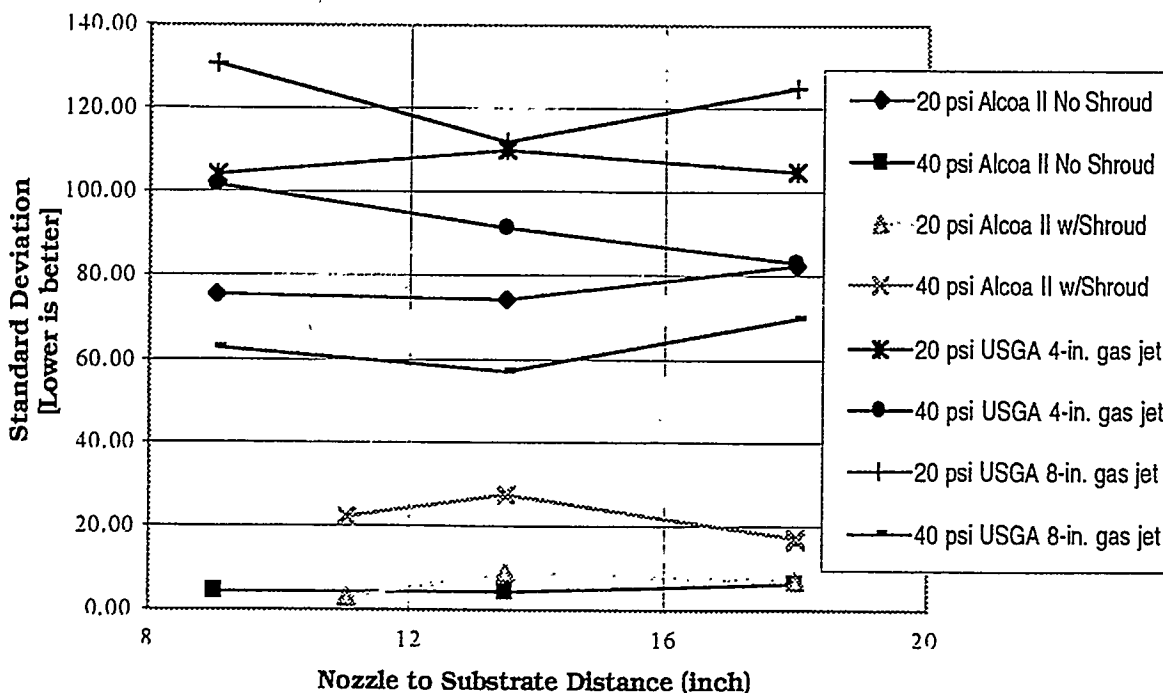
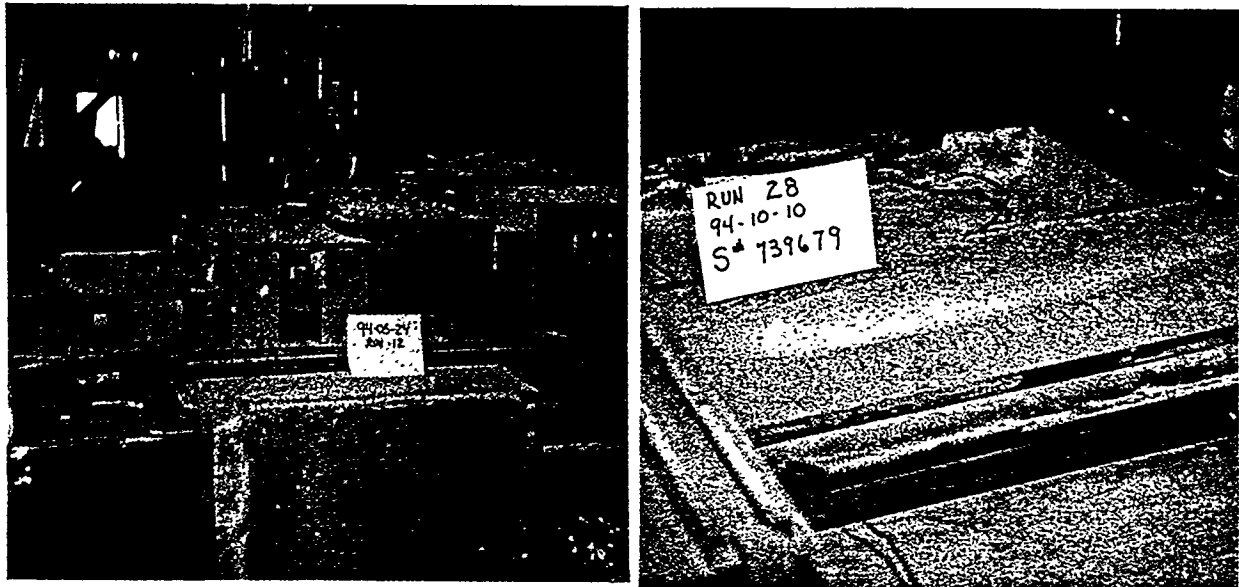

Figure 9. Effect of Nozzle Geometry and Process Parameters on the Deposit Profile Flatness.

Only the most promising nozzle geometries and process parameters found using water were selected for molten metal spray tests with aluminum alloy 3003. Alcoa has performed over 40 metal spray trials using all three of the candidate nozzles. Every run was videotaped and each deposit was evaluated using three main criteria: surface profile (flatness), internal structure (porosity and microstructure), and yield. Figure 10 shows typical pictures of spray formed deposits.



Effect of Substrate Distance.

Typical Deposit. Note "Feathering" Effect.

Figure 10. Spray Formed 3003 Aluminum Alloy.

DISCUSSION

The use of water and air as surrogate materials for the atomized fluid and gas furnished a safe environment in which to carry out the investigation. Alcoa's multi-step analysis provided much insight into the complex interactions between the linear nozzle geometry and process parameters and their effect on the spray plume and final spray deposit.

Using high and standard speed photography, we were able to select a range of operating parameters that minimized re-entrainment of particles and deposition on the atomizing nozzle.

An analysis of the spray patterns via dynamic pressure measurements showed that the impingement angle of the jets, α , and its interaction with the nozzle's vertical offset, V , play a major role in the width of the plume, the peak gas velocity in the vicinity of the metal exit, and the vertical rate of decay of the jet velocity within the plume. Since the liquid metal droplet will flow in the same direction of the gas, narrow gas distributions are favored to constrain the deposit and minimize overspray and edge effects. In addition, a fast pressure decay is advantageous in promoting particle breakup while avoiding excessive acceleration of the particles to the substrate, which promotes splashing.

This technique, by itself, can not be used to select absolute pressure ranges. A thorough understanding of the relationship between gas pressure, P , and particle size distribution and between particle size and the amount of in-flight liquid cooling/solidification is required.

PDPA measurements made at Alcoa verified many of the trends seen with the pitot tube technique. For a given geometry and gas pressure, the liquid particles will travel with similar velocity vectors as the gas. The final particle size distribution arriving at the substrate is a function of the gas speed. In addition, the drop size will affect the drop momentum, drag, and trajectory. A key parameter that can be used to characterize particle/gas interactions is the Stokes number (St)¹ [4]. Droplets with $St \ll 1$ track the velocity vectors accurately. For $St \gg 1$ the trajectory of the droplets is not influenced by the gas flow field. Droplets with a $St \sim 1$ will have their paths influenced by local fluctuations in the gas plume. CMU's PDPA measurements furthermore showed, as expected, that droplet size decreases as atomizing pressure increases. However, there is a limit to the effectiveness of increasing pressure, beyond which any additional gas produces a sensibly constant droplet size.

After completion of the water spray deposition studies we found that the Alcoa II nozzle achieved the best mass flux profile of all the nozzle combinations. The flattest profiles were achieved using a shroud to contain the plume, at medium nozzle pressures and with a simple linear slit design on the liquid side. All mass profiles were similar when operating without the shroud.

Our evaluation noted that the USGA four inch gas jet will become axisymmetric (round) with a parabolic or gaussian deposit at typical nozzle-to-substrate distances of 12-20 inches. The consistently similar results of the USGA nozzle and the unshrouded Alcoa II nozzle water spray results prompted a re-examination of the nature of the gas jet expansion from a linear nozzle. A review of the literature for the expansion characteristics of 3-D rectangular gas jets [5, 6] yielded an understanding of the effects of gas entrainment. This analysis noted that to maintain a rectangular gas profile at the larger than 12 inch substrate distances, L_g must be increased. Based on these results the eight inch L_g USGA nozzle was designed and tested.

An analysis of the 3003 aluminum alloy spray runs provided similar trends as those noted with water. The deposit's cross section typically had a gaussian distribution. A review of the videos and micro-structural analysis showed that the cold, semi-solidified particles found at the edges of the spray plume are a large contributing factor to substrate-side interconnected porosity, feathering and overspray losses. These phenomena are further aggravated by metal splashing and/or bouncing when droplets impact the substrate or deposit. Naber and Reitz [7] developed a jet impingement model based on the Weber number (We)² to determine if a droplet would bounce, slide and spread or splash-off smaller particulate when coming in contact with a wall. Their work noted that at We lower than 80 the droplet would bounce off the surface of film. At We values higher than 80 the impinging droplet would slide and spread across the surface.

The droplet size distribution varied widely among the three linear nozzles evaluated, this in turn affected the extent of solidification of individual particles arriving at the substrate. As noted in Figure 10, the extent of solidification of the arriving particles will determine the heat transfer dynamics at the substrate. Bulk porosity also becomes an issue when the deposit is too dry (particles have high solid content), or too wet (low solid content).

$$^1 St = \frac{\text{Particle Aerodynamics}}{\text{Gas Turbulence}} = \frac{\tau_d U_{CL}}{r_{1/2}} \quad \text{Where } \tau_d = \frac{\rho_l d^2}{18\mu_a} \text{ and } r_{1/2} = \text{Gas flow half radius.}$$

$$^2 We = \frac{\text{Inertial Force}}{\text{Surface Tension Force}} = \frac{V^2 \rho L}{\sigma g_c} \quad \text{Traditionally } L \text{ is a characteristic length defined in this case as the particle diameter. Naber and Reitz used the particle radius in their original paper. In this paper we have translated these to traditional Weber Numbers.}$$

SUMMARY CONCLUSIONS

- Uniformity of the spray pattern is one of the major issues that must be addressed for the production of sheet products. The distribution of gas and molten metal across the nozzle width needs to be uniform to control the deposition.
- Dynamic pressure profiling of the spray plume has proven to be a viable method of visualizing the effect of geometry and processing parameters.
- Phase Doppler Particle Analysis provides a more detailed characterization of the spray plume, verifying the results of the pitot tube measurements.
- Use of a shroud gives a two-fold effect towards improving the linear characteristics of the spray plume. One, the inherently lower aspect ratio maintains the linear profile of the jet farther downstream. The second is due to the fact that the nozzle exit from the shroud will be closer to the substrate.
- The 3-D analysis of gas jets indicates that we require nozzles with an L_g longer than four inches to see a flat middle section in a deposit.

In this study there have been a number of geometric re-designs of the spray forming nozzles aimed at maintaining intimate contact between the gas and liquid. These have yet to simultaneously produce the deposit **profile, yield, and bulk properties** needed at the **production rates** required to meet our program objectives. Work continues on these and other deposition systems which have shown potential to solve these needs.

REFERENCES

- [1] Singer, A. R. E., "The Principles of Spray Rolling of Metals". *Metal and Materials*, Vol. 4, p. 246, 1970
- [2] Ando, T., Tsao, C-Y., Wahlroos, J. and Grant, N. J., "Analysis and Control of Gas Atomization Rate", *The International Journal of Powder Metallurgy*, Vol. 26, No. 4, 1990
- [3] Moir, S. A., Jones, H., "The Gas Velocity Profile of a Free Fall Atomizer and its Relation to Solidification Microstructure of Collected Spray Droplets of 2014 Aluminum Alloy", *Materials Science and Engineering*, A173, 1993
- [4] Mansour, A. and Chigier, N., "The Near Field of Co-axial Air Blast Atomizer Sprays". Unpublished paper. 1995
- [5] Trentacoste, N. and Sforza, P., "Further Experimental Results for Three-Dimensional Free Jets", *AIAA J.* Vol. 5 No. 5, pp. 885-891, 1967
- [6] Sfeir, A. A., "Investigation of Three-Dimensional Rectangular Turbulent Jets", *AIAA Proceedings*, pp. 1-9, 1978
- [7] Naber, J. D. and Reitz, R. D., "Modeling Engine Spray/Wall Impingement". *SAE Paper* 880107. 1988

ACKNOWLEDGMENTS

The authors would like to acknowledge the Department of Energy, Carnegie-Mellon University, and Massachusetts Institute of Technology for their support of this work under Agreement # DE-FC07-94 ID 13238. In addition we would like to recognize all the members of Alcoa's Spray Forming Team for their contributions to this paper.

DISCLAIMER

This report was prepared as an account of work sponsored by an agency of the United States Government. Neither the United States Government nor any agency thereof, nor any of their employees, makes any warranty, express or implied, or assumes any legal liability or responsibility for the accuracy, completeness, or usefulness of any information, apparatus, product, or process disclosed, or represents that its use would not infringe privately owned rights. Reference herein to any specific commercial product, process, or service by trade name, trademark, manufacturer, or otherwise does not necessarily constitute or imply its endorsement, recommendation, or favoring by the United States Government or any agency thereof. The views and opinions of authors expressed herein do not necessarily state or reflect those of the United States Government or any agency thereof.

APPENDIX I. Photographic Essay of the Various Atomizing Nozzles
(Gas = air Liquid = water)



Standard Configuration of the USGA Nozzle

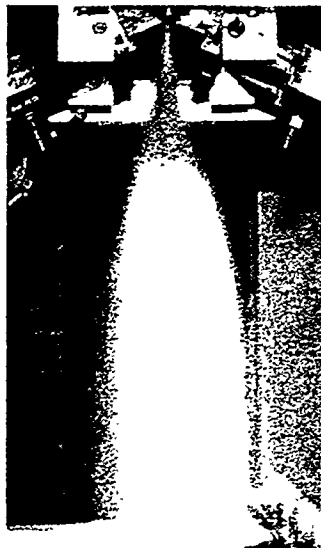

(Wide Spray)



(Offset Spray)

Effect of Changing Operating and Geometric Parameters

APPENDIX I (cont.). Photographic Essay of the Various Atomizing Nozzles
(Gas = air Liquid = water)

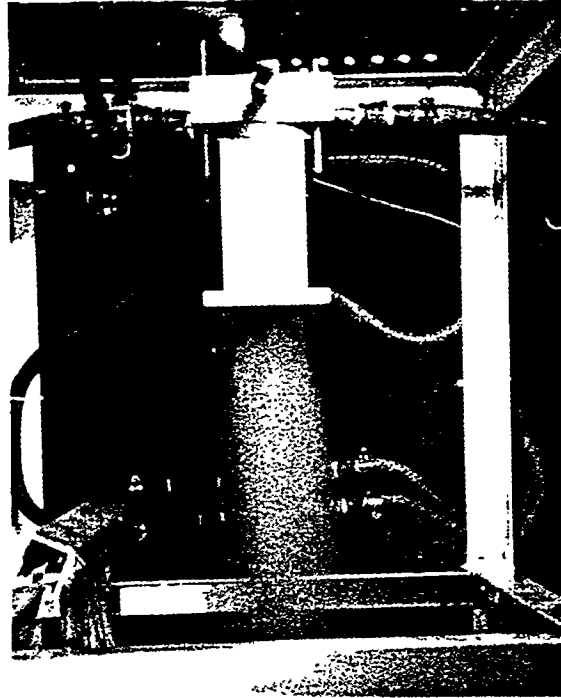

Standard Configuration of the ALCOA II Nozzle

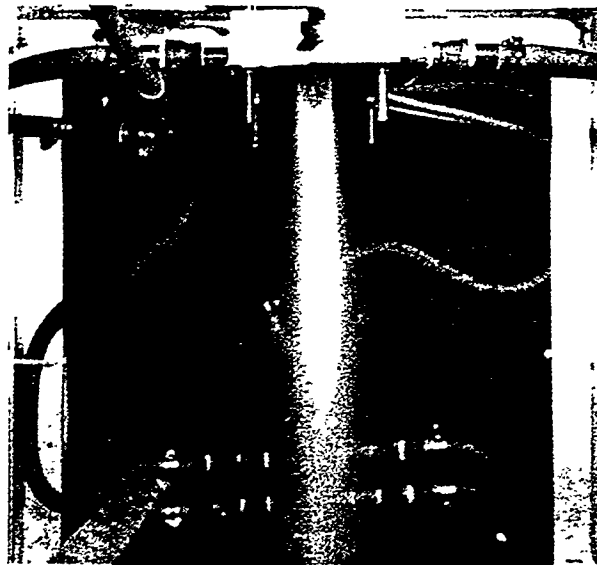

ALCOA II Nozzle With Shroud Removed

APPENDIX II. Spray Profiles Via Pitot Tube Measurements

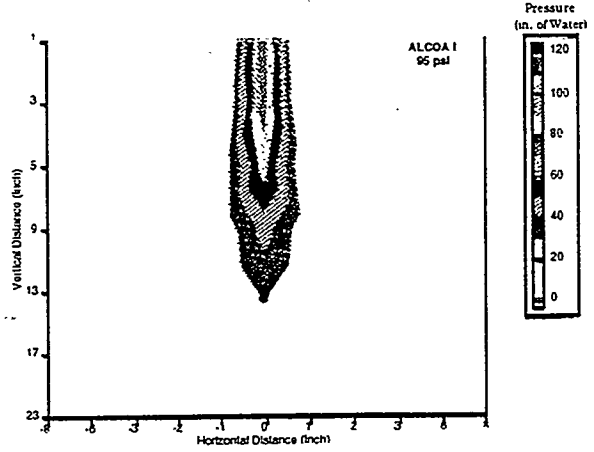
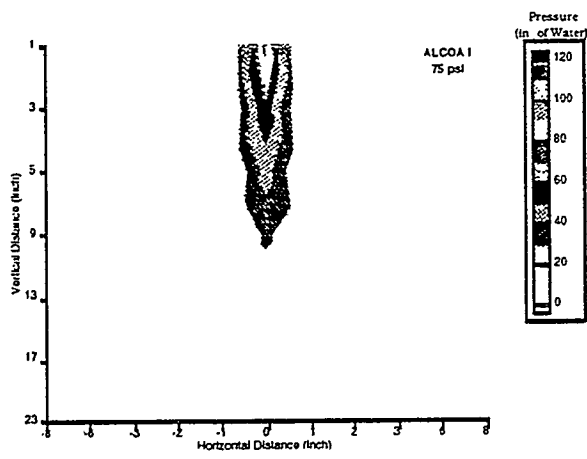

USGA Nozzle

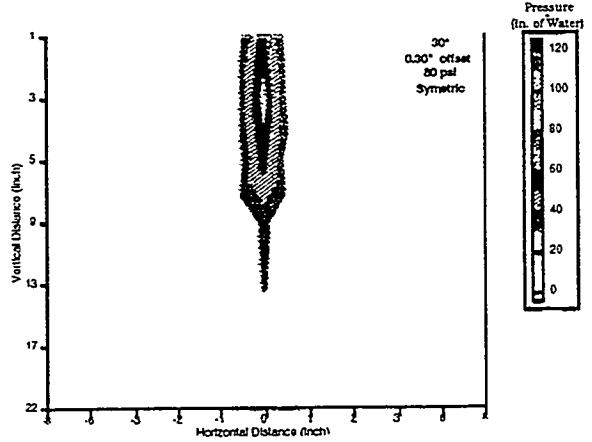
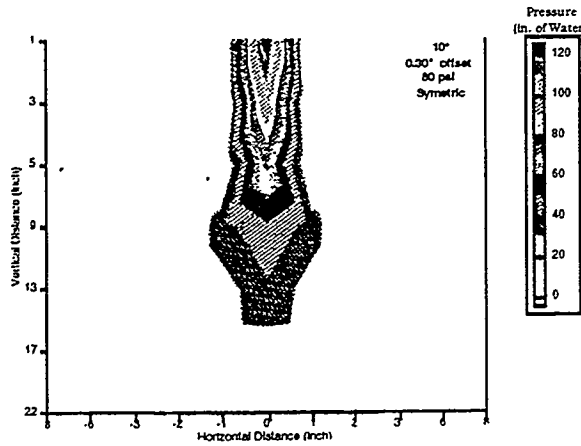
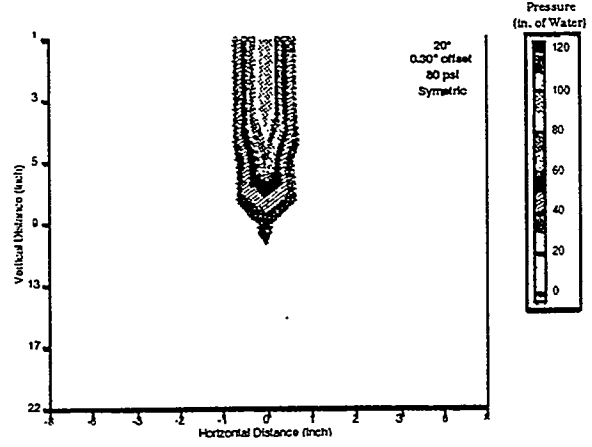
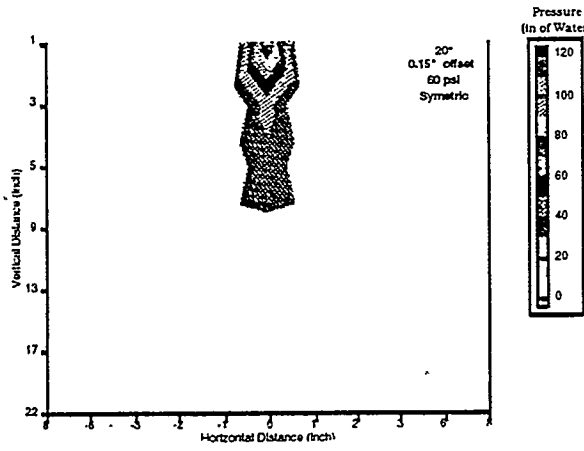

APPENDIX II (cont.). Spray Profiles via Pitot Tube Measurements

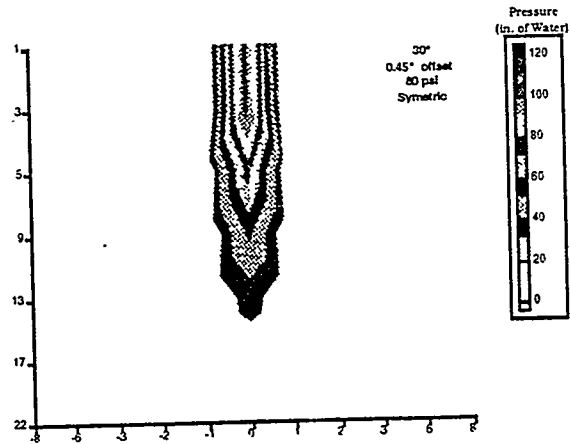
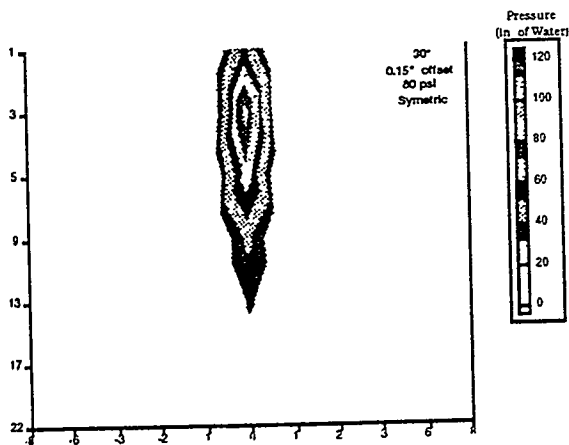

USGA Nozzle - Asymmetric gas jets

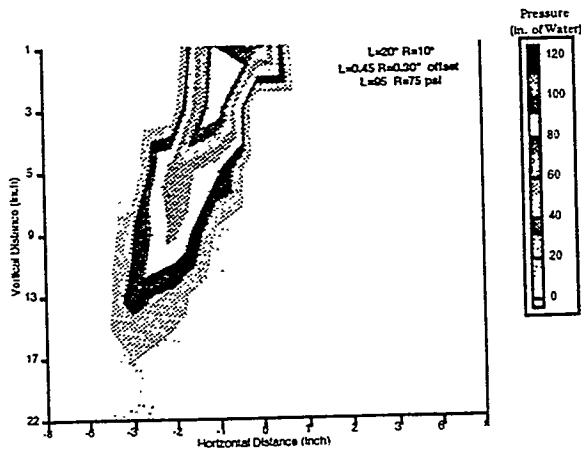
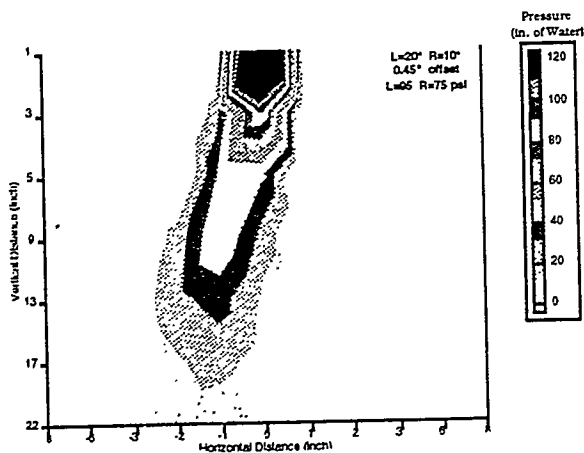
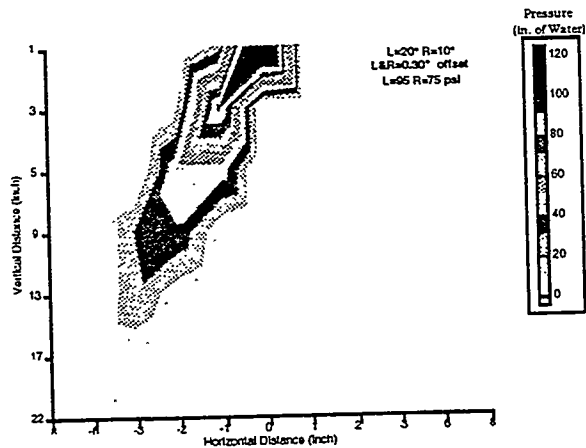
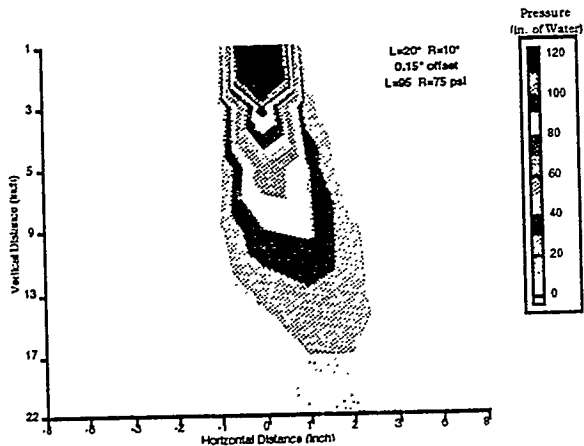

APPENDIX III. Water Deposition Profiles as a Function of Geometry and Process Parameters

Profile

Spray Parameters

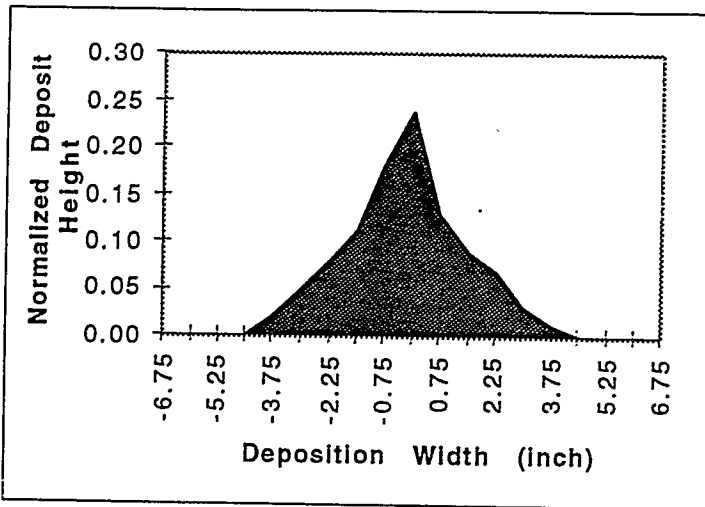

USGA Nozzle
8" L_g
20 psi gas pressure
18" Nozzle-to-Substrate Distance

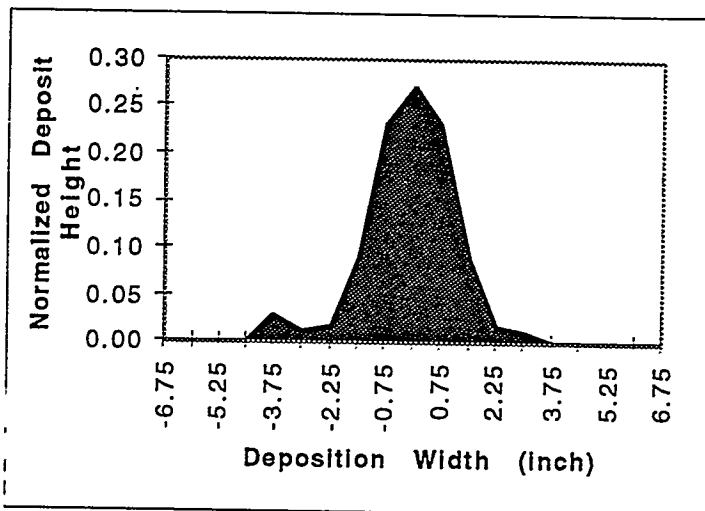

USGA Nozzle
4" L_g
20 psi gas pressure
18" Nozzle-to-Substrate Distance

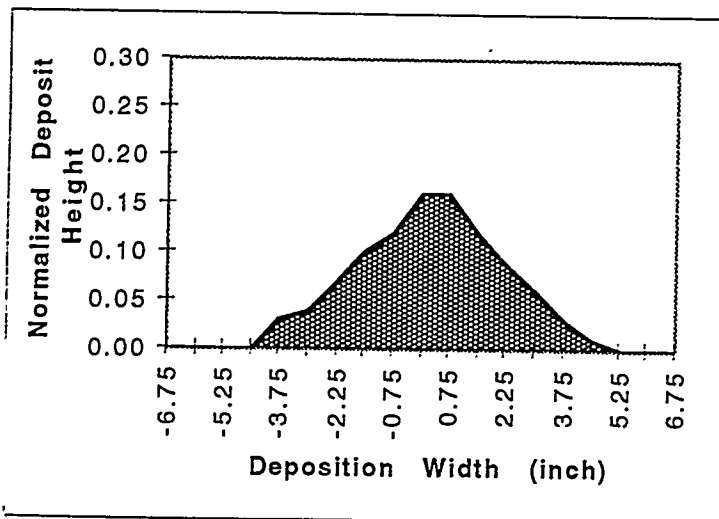

USGA Nozzle
8" L_g
40 psi gas pressure
18" Nozzle-to-Substrate Distance

APPENDIX III (cont.). Water Deposition Profiles as a Function of Geometry and Process Parameters

Profile

Spray Parameters

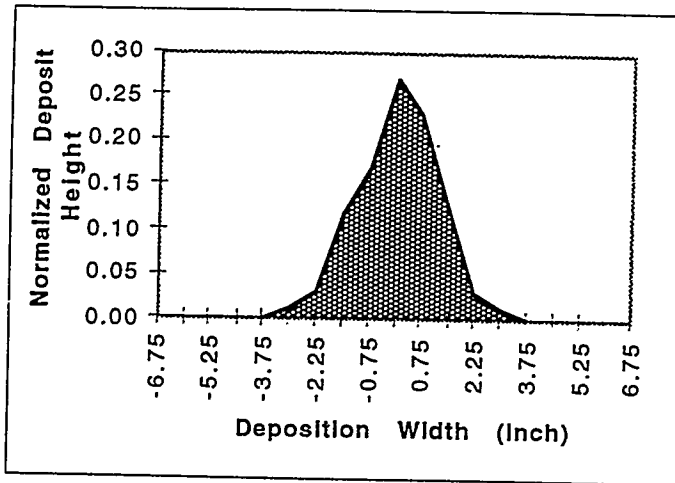

USGA Nozzle
 4" L_g
 40 psi gas pressure
 18" Nozzle-to-Substrate Distance

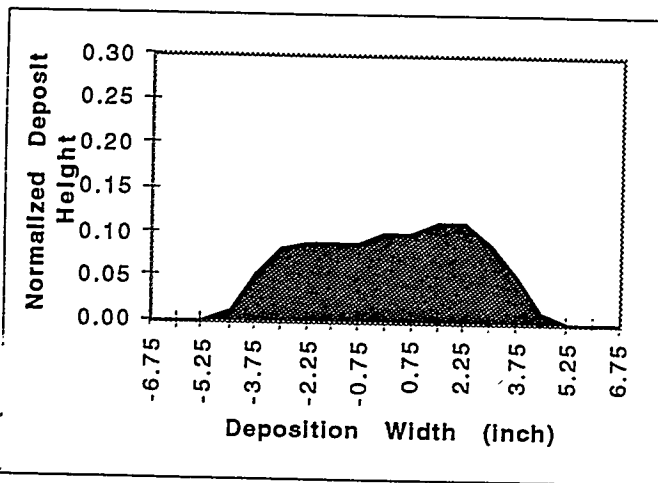

ALCOA II Nozzle
 7" Shroud Installed
 20 psi gas pressure
 18" Nozzle-to-Substrate Distance

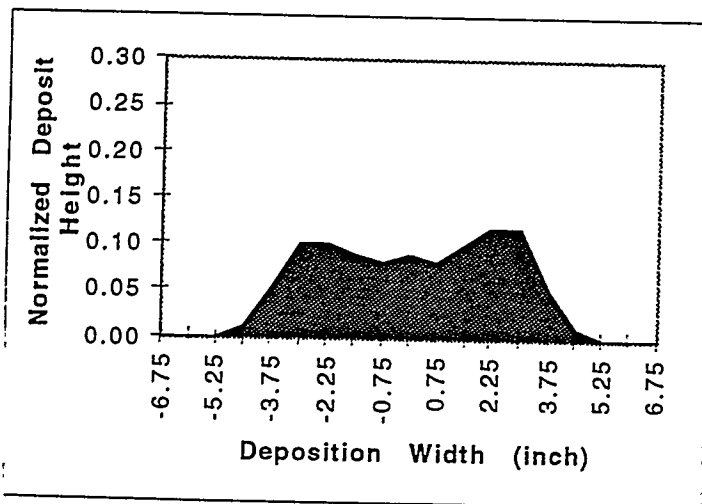

ALCOA II Nozzle
 7" Shroud Installed
 40 psi gas pressure
 18" Nozzle-to-Substrate Distance

APPENDIX III (cont.). Water Deposition Profiles as a Function of Geometry and Process Parameters

